

BECAUSE YOU
CAN BREATHE DEEPLY!
TAKE A BREATH!

WHY SHOULD I
WASTE MY TIME,
WITH THINKING ABOUT
WASTE?

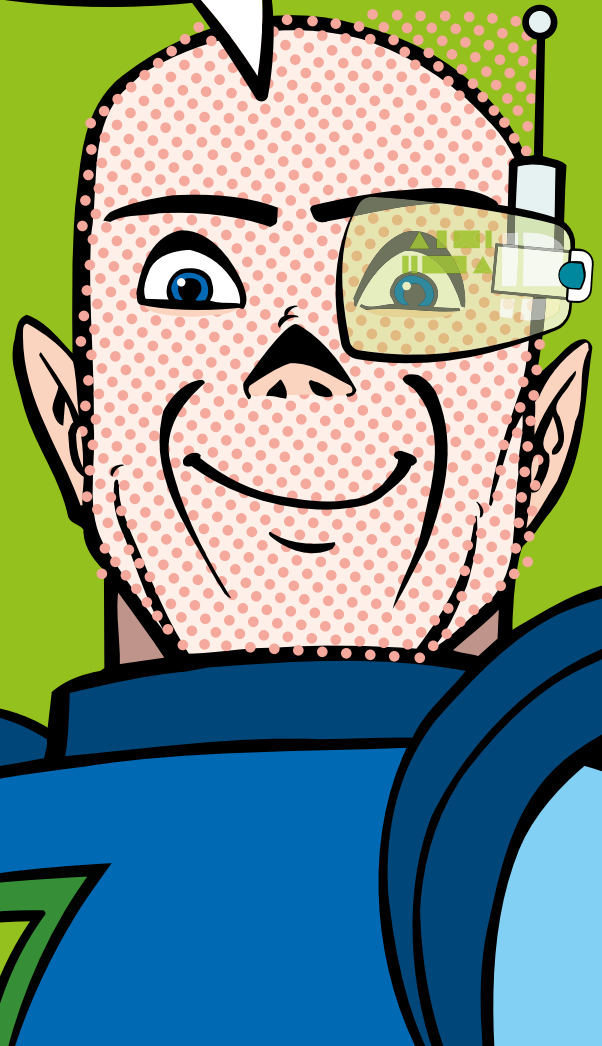
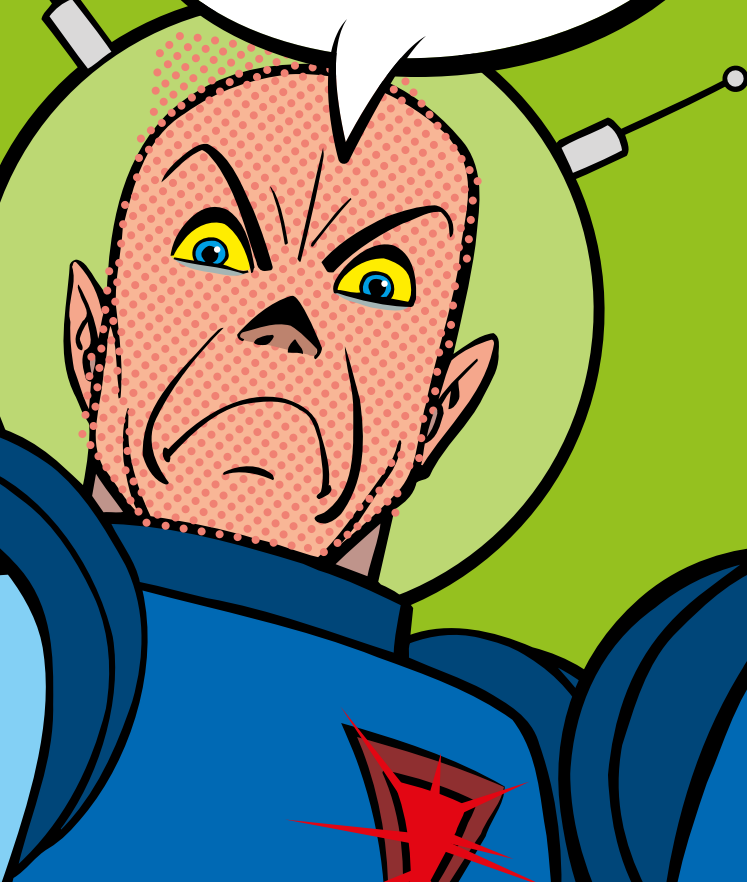

Keep your Head clear - for your daily, Analytical Work.

Working in the laboratory requires high concentration and a safe environment. Safety Waste Caps turn every collection container into a closed system according to the latest safety standards. This allows you to concentrate on your tasks undisturbed.

Алматы (727)345-47-04
Ангарск (3955)60-70-56
Архангельск (8182)63-90-72
Астрахань (8512)99-46-04
Барнаул (3852)73-04-60
Белгород (4722)40-23-64
Благовещенск (4162)22-76-07
Брянск (4832)59-03-52
Владивосток (423)249-28-31
Владикавказ (8672)28-90-48
Владимир (4922)49-43-18
Волгоград (844)278-03-48
Вологда (8172)26-41-59
Воронеж (473)204-51-73
Екатеринбург (343)384-55-89

Иваново (4932)77-34-06
Ижевск (3412)26-03-58
Иркутск (395)279-98-46
Казань (843)206-01-48
Калининград (4012)72-03-81
Калуга (4842)92-23-67
Кемерово (3842)65-04-62
Киров (8332)68-02-04
Коломна (4966)23-41-49
Кострома (4942)77-07-48
Краснодар (861)203-40-90
Красноярск (391)204-63-61
Курск (4712)77-13-04
Курган (3522)50-90-47
Липецк (4742)52-20-81

Магнитогорск (3519)55-03-13
Москва (495)268-04-70
Мурманск (8152)59-64-93
Набережные Челны (8552)20-53-41
Нижний Новгород (831)429-08-12
Новокузнецк (3843)20-46-81
Ноябрьск (3496)41-32-12
Новосибирск (383)227-86-73
Омск (3812)21-46-40
Орел (4862)44-53-42
Оренбург (3532)37-68-04
Пенза (8412)22-31-16
Петрозаводск (8142)55-98-37
Псков (8112)59-10-37
Пермь (342)205-81-47

Ростов-на-Дону (863)308-18-15
Рязань (4912)46-61-64
Самара (846)206-03-16
Санкт-Петербург (812)309-46-40
Саратов (845)249-38-78
Севастополь (8692)22-31-93
Саранск (8342)22-96-24
Симферополь (3652)67-13-56
Смоленск (4812)29-41-54
Сочи (862)225-72-31
Ставрополь (8652)20-65-13
Сургут (3462)77-98-35
Сыктывкар (8212)25-95-17
Тамбов (4752)50-40-97
Тверь (4822)63-31-35

Тольятти (8482)63-91-07
Томск (3822)98-41-53
Тула (4872)33-79-87
Тюмень (3452)66-21-18
Ульяновск (8422)24-23-59
Улан-Удэ (3012)59-97-51
Уфа (347)229-48-12
Хабаровск (4212)92-98-04
Чебоксары (8352)28-53-07
Челябинск (351)202-03-61
Череповец (8202)49-02-64
Чита (3022)38-34-83
Якутск (4112)23-90-97
Ярославль (4852)69-52-93

Россия +7(495)268-04-70

Казахстан +7(727)345-47-04

Беларусь +(375)257-127-884

Узбекистан +998(71)205-18-59

Киргизия +996(312)96-26-47

<https://scat.nt-rt.ru/> || sqt@nt-rt.ru

HPLC-Disposal

- ✓ Bind Solvent Vapours Safely
- ✓ Safely Bind Acid and Alkaline Vapours
- ✓ Reliable Occupational Safety
- ✓ Clean Laboratory Air

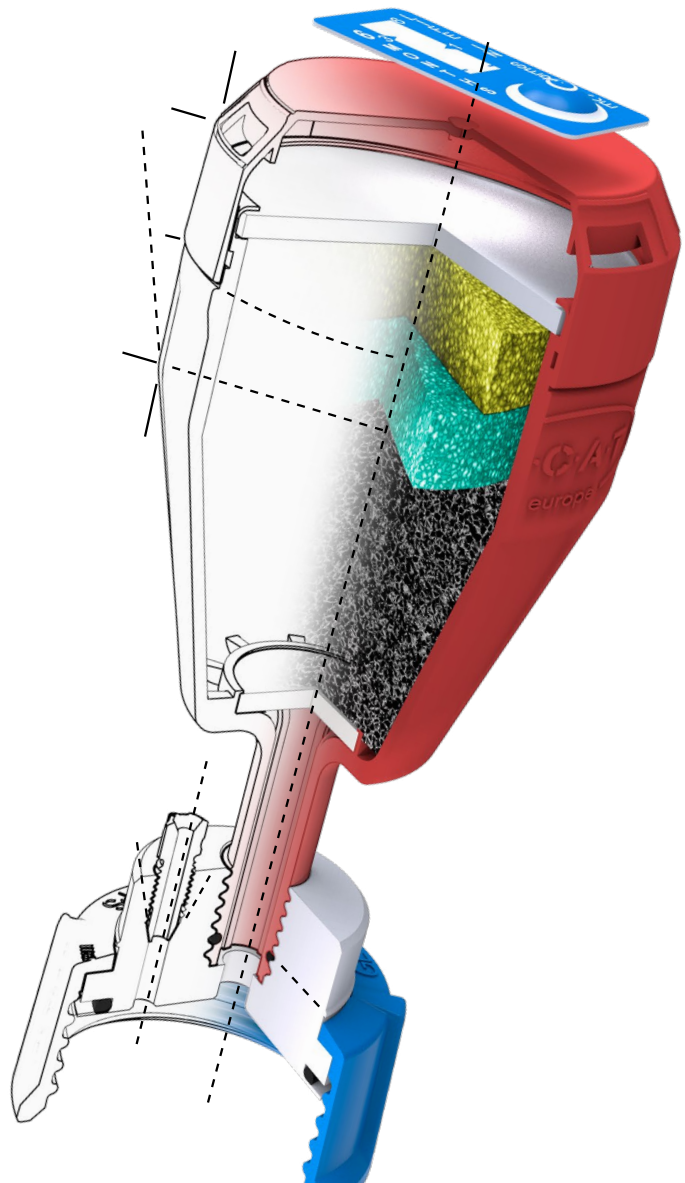

Do you Collect your HPLC-Waste Safely?

Safety Waste Caps - one system for all threads.

The liquids in the waste containers in laboratories are highly hazardous to health - users are often unaware of the mixtures that can arise in the canisters. Closed safety systems from SCAT Europe offer effective protection and additionally guarantee economical work in the laboratory.



You know This? Comparison



Improper disposal of
laboratory waste.



Safe disposal with SCAT
Safety Waste Cap.



Activated Carbon: What is Important?

SCAT activated carbon protects against solvent, acid and alkali vapours.

History

The beginnings of activated charcoal lie in the use of one of its predecessors in the production chain: charcoal! The first evidence that charcoal was used to purify water dates back to 200 BC. Chr.

Columbus charred the insides of wooden barrels to increase the durability of the water being transported. The first industrial use of charcoal was in 1794 in an English sugar refinery.

What is activated carbon?

Activated carbons are industrially (-> artificially) manufactured products from carbonaceous materials such as hard coal, lignite, wood, peat with a high internal, adsorptive surface. Activated carbon consists mainly of carbon (usually > 90%) with a highly porous structure. The pores are interconnected like a sponge.

Manufacturing process

The starting material (hard coal, lignite, wood, peat,.. -> the primary coal) is charred, i.e. burned without oxygen supply. Almost everything that is not carbon is burned, resulting in a winding tunnel system with only very small pores. The raw activated carbon produced in this way is then activated. The active pore system is created by removing volatile components (hydrogen, oxygen, nitrogen, sulfur, etc.).

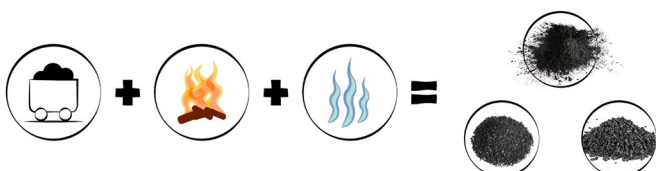

Basic functionality

The fluid loaded with the pollutant flows through a layer of activated carbon at a certain speed, and releases the pollutant to the activated carbon. Any decrease in concentration of the fluid leads to an increase in the loading on the activated carbon. The activated carbon basically retains vaporous or dissolved substances only. Any dust or suspended matter must first be separated out by other filters (-> SCAT uses a pre-filter -> PE frit), otherwise they would contaminate the activated carbon.

Appropriate conductive devices inside the exhaust air filter housing must ensure that the fluid does not preferentially flow along the housing wall (-> flow resistance, problem of edge movement), but rather passes the activated carbon in the full cross-section.

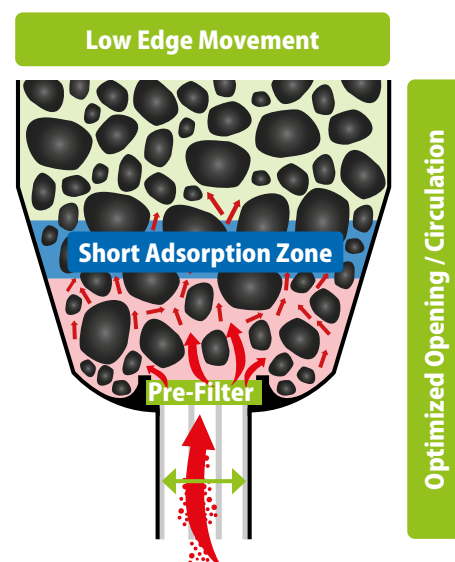



The SCAT specifications

No.	Attribute	Value	Test Method
1.	Ball-Pan-Hardness (% of weight)	96 %	ASTM D 3802
2.	Inner Spec. Surface	1,500 m ² /g	DIN ISO 9277
3.	Bulk Density	415 ± 30 kg/m ³	ASTM D 2854
4.	CTC-Adsorption (% of weight)	> 90 %	ASTM D 3467
5.	Particle Diameter	1.4 - 3 mm	ASTM D 2862
6.	Ash Content (% of weight)	max. 5 %	ASTM D 2866
7.	Specific Humidity (% of weight)	max. 5 %	ASTM D 2867

1. Ball-Pan-Hardness

The abrasion number measures the resistance of the activated carbon to wear. It is measured in the so-called ball pan hardness, according to ASTM D3802, in percent by weight. The principle is as follows: the activated carbon is placed on a vibrating screen. After 30 minutes, it is determined how many particles have fallen through the sieve. The fewer fall through, the better. I.e. the abrasion / "impact strength" etc. is higher. With a ball pan hardness of 96%, only 4% have fallen through.

2. Inner Specific Surface

The inner surface of porous or granular solids includes all of the surfaces they contain, including those between the individual grains or through the edges of the pores. Since all chemical reactions essentially depend on the "size of the attack" surface compared to the volume, the inner surface is of great importance.

3. Bulk Density

Density is mass per unit volume ($\rho = m/V$). The density of gold is: 19,300 kg/m³. The density of pure carbon is 2,250 kg/m³. The tapped density (synonym: tapped density) is obtained by mechanically shaking or tapping the sample in a measuring cylinder until it no longer shows a significant reduction in volume. Basically, it can be said that the lower the fill density, the higher the porosity, and the higher the activation and quality of the activated carbon.

4. Adsorption

Adsorption refers to the absorption capacity (saturation) of the carbon. The adsorbed mass of pollutants is related to the mass of the fresh activated carbon and is called the loading. It is given in percent. With our activated carbon, the adsorption of CCl₄ (= carbon tetrachloride activity) is 90%. CCl₄ was defined by the activated carbon industry as a standard reference value with a net weight of 100 grams, the activated carbon weighs 190 grams when fully loaded - unique performance value!

5. Particle Diameter

The particle diameter describes the size of individual particles (also called grains) in a mixture. Depending on the application, a certain grain diameter is required. If the grain diameter is too small / powdery for our application, then sticking occurs that can only be overcome by high flow pressure.

6. Ash Content

In addition to carbon, activated carbon also contains inorganic components of the raw material that have not evaporated during production. Calcium, iron, zinc, copper, lead, chlorine, sulfate, phosphate, HCl-soluble substances and ash should be named here. Apart from the HCl-soluble substances (approx. 5%) and ash (approx. 10%), all other substances are below 0.5%. Since ash makes up the largest proportion, ash is often given as a reference value (the smaller the better). The ash consists mainly of silicon dioxide and aluminum. The amount depends on the base raw material used to produce the activated carbon. This means that the lower the ash content, the less ineffective minerals are in it and the more effective carbon.

7. Specific Humidity

Specific humidity is measured as a percentage by weight. The lower the water content the better. You don't want water because it's ineffective. The ash content and the water content must be considered together. This means that a low ash content and low water content ensure that the activated carbon contains as much carbon as possible and a high level of effective activated carbon.

Safety Waste Caps

Functional Principle

✓ Resistant to Aggressive Chemicals

Through the use of pure PTFE and PE-HD Safety Waste Caps are resistant to organic solvents, acids and alkalis.

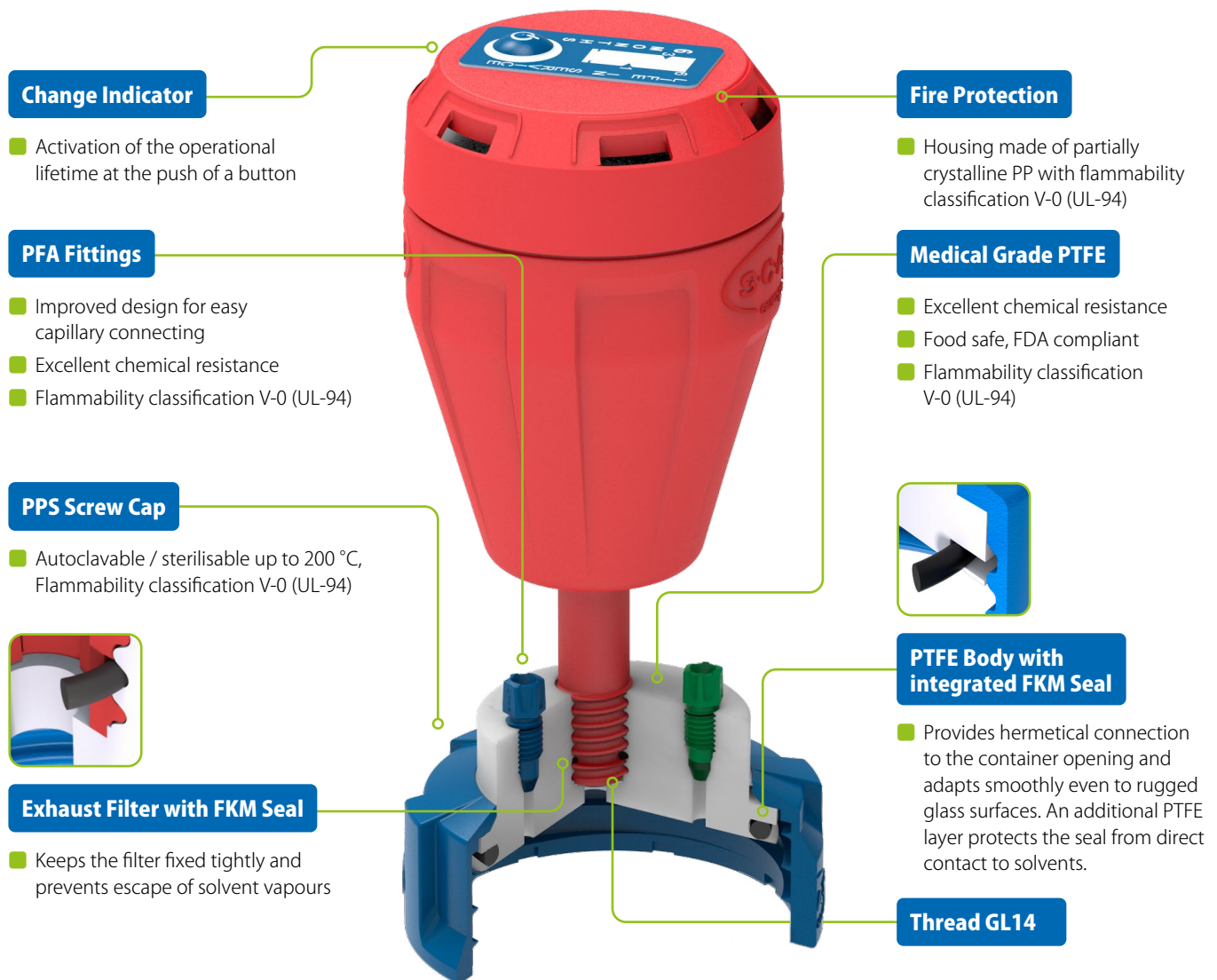

Consistent with Safety Waste Caps

Exhaust Filter.....	on page 71
Accessories for the exhaust filter conn.	on page 154
Accessories for the capillary connection...	on page 156
Accessories for the tube connection	from page 158
Canisters.....	from page 136



What means fire protection according to UL-94?

In case of fire, each second counts. Flame resistant materials can save lives and provide rescue teams with more time to react in case of an emergency. UL-94 is an international standard to classify the flammability of plastics. UL-94 can also be found in IEC/DIN EN 60695-11-10 and -20. V-0 is the highest classification with the following requirements to the plastic material:

- Burning stops within 10 seconds on a vertically fixed specimen
- No drips of inflamed particles allowed
- Maximum afterglow of 30 seconds

Safety Waste Caps

Technical Details

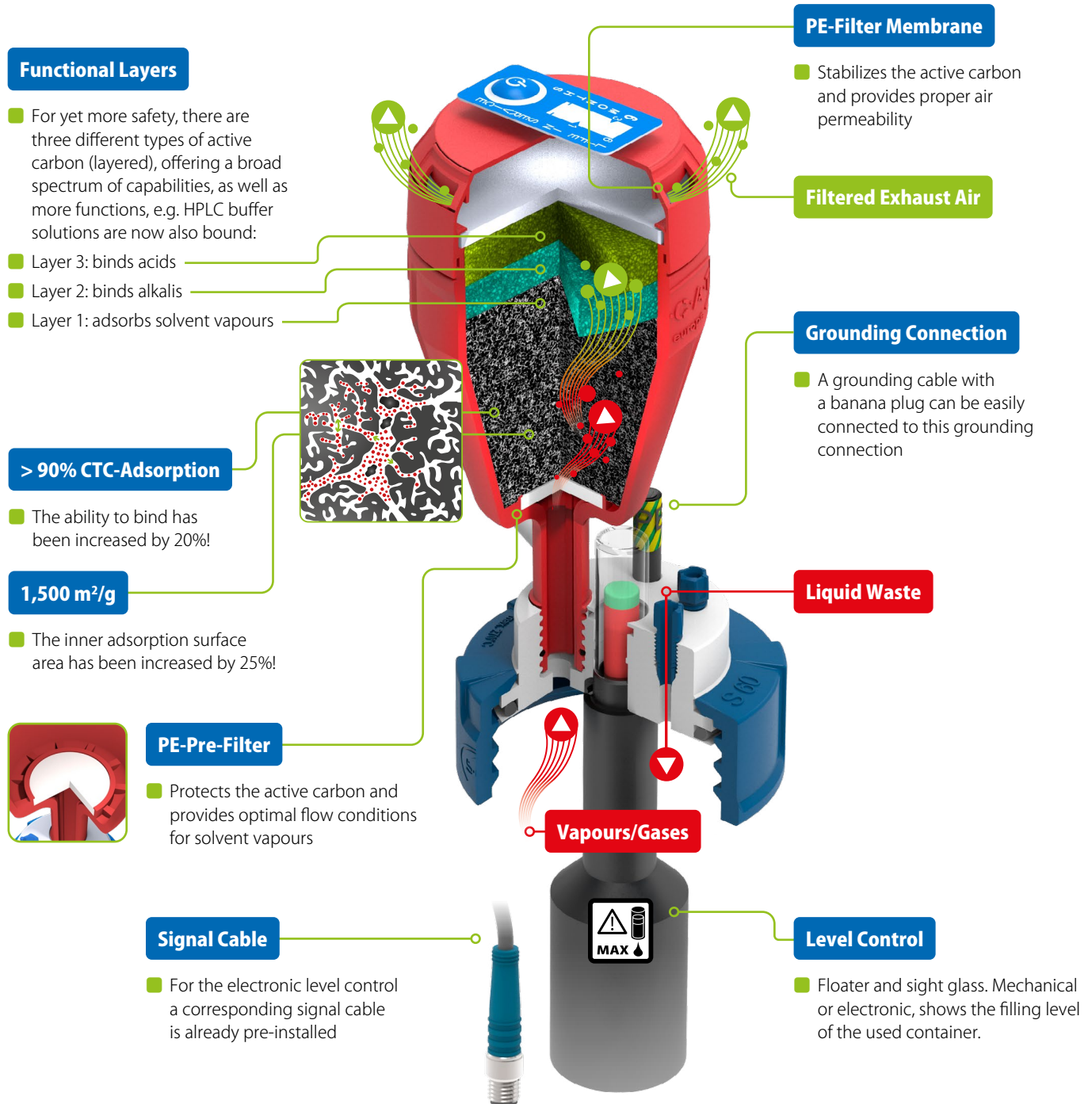

Filter system against harmful vapours.

Exhaust filters in different sizes and with various operational lifetimes can be found on **page 71**.



Do you already have the right container?

Use Safety Waste Caps on your existing containers, or order matching canisters! From **page 136**.

The SCAT Exhaust Filter for Safety Waste Caps

Expeded filters? - Exchange regularly!

The exhaust filter is optimized for the adsorption of solvent vapours from eluents, as typically used for HPLC. The actual lifetime of the filter is also dependent upon the composition of the waste material being produced, its temperature and flowrate. These factors can vary considerably from customer to customer, and/or according to the nature of the application. In order to be on the safe side, we recommend an exchange every 3 (Filter S); 6 (Filter M); 12 (Filter L) months*, for optimum protection.



Change indicator

Easy activation at the touch of a button!

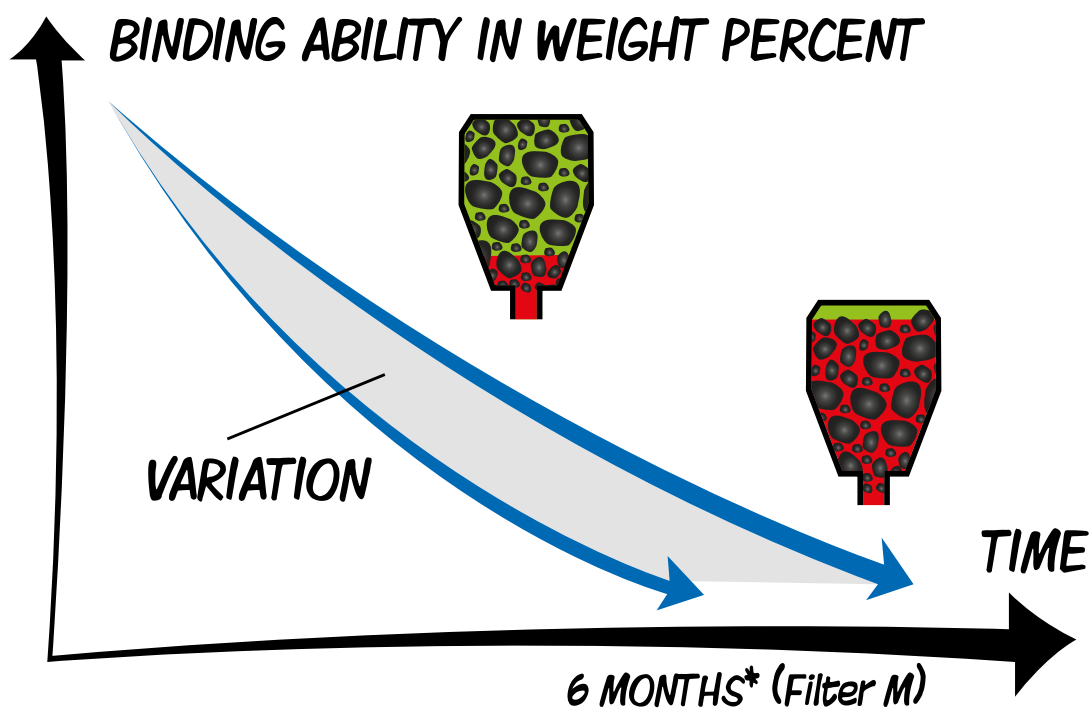

*Operational lifetime with typical HPLC flowrates of 1.5 - 4.0 ml per minute.

The SCAT Exhaust Filter 12 Months of Safety

A 490 335



Operational
Lifetime
12
MONTHS

4x Exchange / Year

B 490 336 -19%**



Operational
Lifetime
12
MONTHS

2x Exchange / Year

C 407 986 -33%**



Operational
Lifetime
12
MONTHS

1x Exchange / Year

**As compared to the exchange pack, Size S.

Fig.	Part No.	Description	Thread	Lifetime per Unit	Unit
	410 534	Exhaust Filter S, V3.0, with splash protection and change indicator	GL 14	3 Months	1
A	490 335	Exhaust Filter S, V3.0, with splash protection and change indicator	GL 14	3 Months	4
	407 982	Exhaust Filter M, V3.0, with splash protection and change label	GL 14	6 Months	1
	410 535	Exhaust Filter M, V3.0, with splash protection and change indicator	GL 14	6 Months	1
B	490 336	Exhaust Filter M, V3.0, with splash protection and change indicator	GL 14	6 Months	2
	490 914	Exhaust Filter M, V3.0, with splash protection and change label	GL 14	6 Months	2
C	407 986	Exhaust Filter L, V3.0, with splash protection and change indicator	GL 14	12 Months	1
	490 986	Exhaust Filter L, V3.0, with splash protection and change indicator	GL 14	12 Months	2
	407 983	Exhaust Filter L, V3.0, with splash protection and change label	GL 14	12 Months	1
	490 915	Exhaust Filter L, V3.0, with splash protection and change label	GL 14	12 Months	2

Safety Waste Caps

State of the Art - Disposal



Laboratory waste under lock.

With SCAT Safety Waste Caps you collect HPLC waste in the safest way possible. Suitable for many different containers, tube and capillary sizes, the SCAT Safety Waste Caps can be individually adapted to your laboratory equipment. With a mechanical or electronic level control you always have the best overview. The world's safest state-of-the-art system.



Connection for exhaust filter

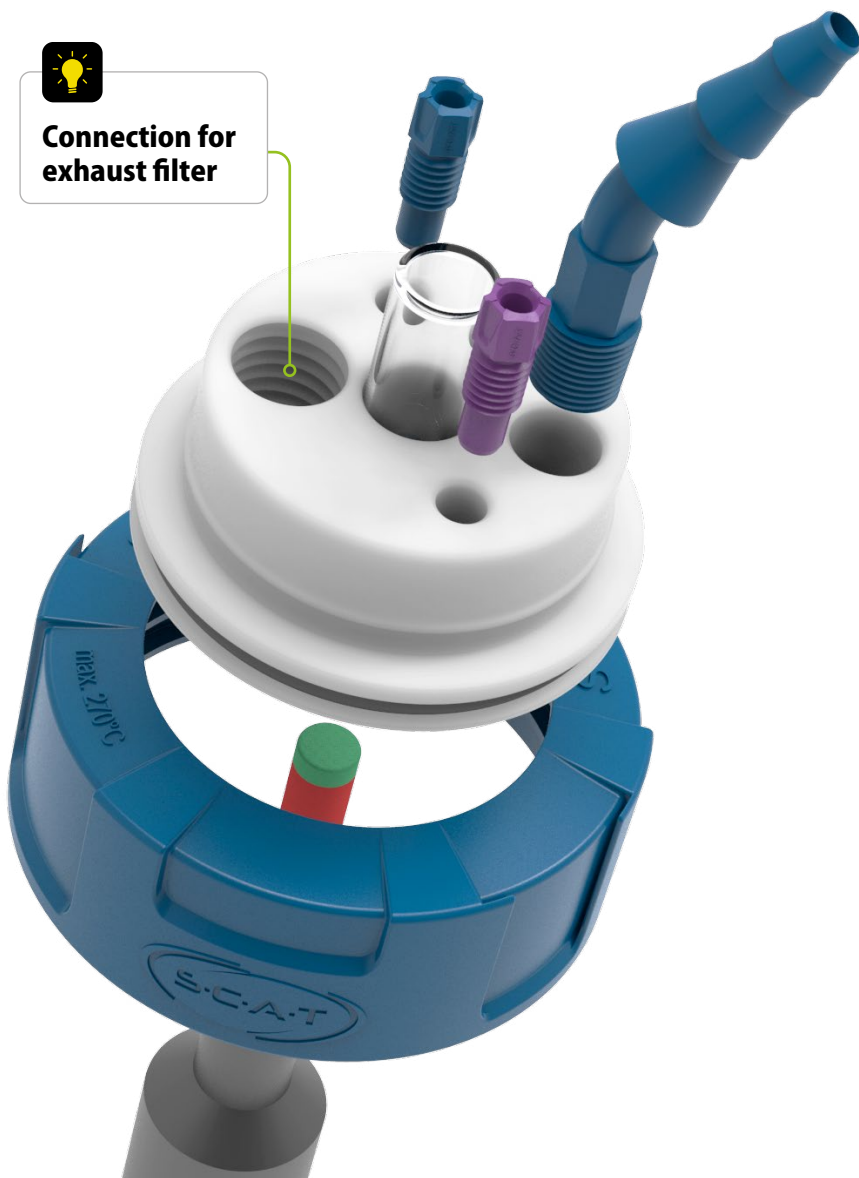

Thread informations

Container threads can be roughly determined based on their diameter. Information on the exact determination of the thread can be found under "Thread determination" from **page 172**.

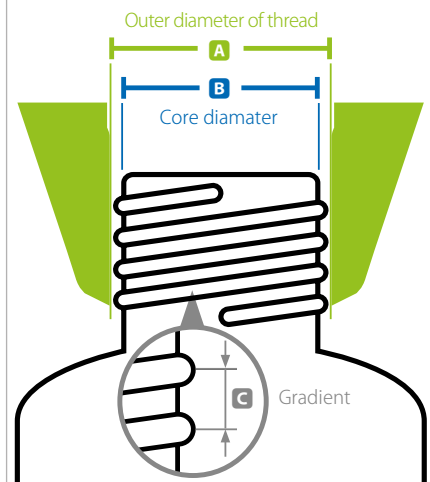

Thread	A Ø (mm)	B Ø (mm)	C (mm)
GL 45	45.00	42.30	4.00
S 50	50.00	46.00	4.00
S 51	51.00	47.00	4.00
B 53	54.00	47.50	6.35
S 55	53.80	49.50	5.00
S 60	60.00	54.00	6.00
B 63	62.51	60.12	4.23
S 65	65.00	59.00	6.00
S 70	71.00	65.00	6.00
GLS 80	80.00	77.00	15P5
B 83	89.18	79.00	12.70
S 90	90.00	84.00	6.00
S 95	95.00	89.00	7.00

Safety Waste Caps State of the Art - Disposal

GL/S 40 - GL 45

A 307 108



B 307 109



Don't forget - exhaust filter!

Suitable exhaust filters with various operational lifetimes for SCAT Safety Waste Caps you will find on **page 71**.



C 307 912



D 307 923



E 308 921



Fig.	Part No.	Description	Thread	Capillary Connections	Tube Connections	Exhaust Filter Connection
A	307 108	Safety Waste Cap	GL/S 40	3	-	●
B	307 109	Safety Waste Cap	GL/S 40	2	1	●
C	307 912	Safety Waste Cap	GL 45	3	-	●
D	307 923	Safety Waste Cap	GL 45	2	1	●
E	308 921	Safety Waste Cap	GL 45	4	1	●

Safety Waste Caps State of the Art - Disposal

A 108 023**B** 108 024**C** 108 025**D** 108 026**E** 108 113**F** 502 031

Fig.	Part No.	Description	Thread	Level Control	Capillary Connections	Tube Connections	Exhaust Filter Connection	Grounding Connection
A	108 023	Safety Waste Cap	S 50	-	3	-	●	-
B	108 024	Safety Waste Cap	S 50	-	3	-	●	●
C	108 025	Safety Waste Cap	S 50	-	2	1	●	-
D	108 026	Safety Waste Cap	S 50	-	2	1	●	●
E	108 113	Safety Waste Cap	S 50	-	3	1	●	-
F	502 031	Safety Waste Cap	S 50	-	5	-	●	-

Safety Waste Caps State of the Art - Disposal

A 107 922

B 107 930

C 107 935

D 107 942

E 107 241

F 107 242

Fig.	Part No.	Description	Thread	Level Control	Capillary Connections	Tube Connections	Exhaust Filter Connection	Grounding Connection
A	107 922	Safety Waste Cap	S 51	-	2	1	●	-
B	107 930	Safety Waste Cap	S 51	-	3	-	●	-
C	107 935	Safety Waste Cap	S 51	-	3	-	●	●
D	107 942	Safety Waste Cap	S 51	-	2	1	●	●
E	107 241	Safety Waste Cap	S 51	Mechanical	2	-	●	-
F	107 242	Safety Waste Cap	S 51	Electronically	2	-	●	-

Safety Waste Caps State of the Art - Disposal

A 107 037

B 107 054

C 107 120

D 107 122

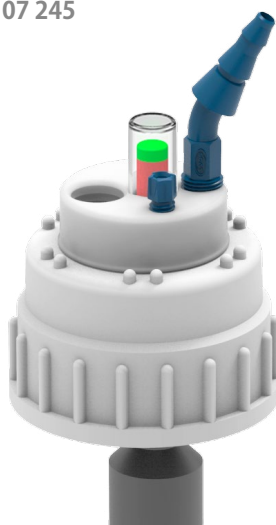
E 107 245

F 107 246



Looking for the right container?

Canisters, bottles and other containers, suitable with the SCAT Safety Waste Caps starting from **page 130**.

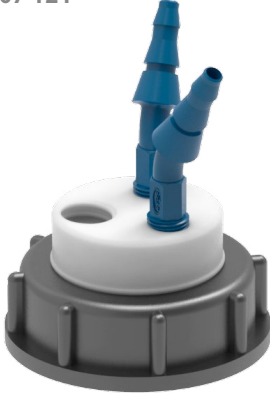

Fig.	Part No.	Description	Thread	Level Control	Capillary Connections	Tube Connections	Exhaust Filter Connection	Grounding Connection
A	107 037	Safety Waste Cap	B 53	-	4	1	●	-
B	107 054	Safety Waste Cap	B 53	-	3	1	●	●
C	107 120	Safety Waste Cap	B 53	-	-	2	●	-
D	107 122	Safety Waste Cap	B 53	-	1	2	●	-
E	107 245	Safety Waste Cap	B 53	Mechanical	1	1	●	-
F	107 246	Safety Waste Cap	B 53	Electronically	1	1	●	-

Safety Waste Caps State of the Art - Disposal

A 107 121

B 107 924

C 107 943

D 108 177

E 108 030

F 108 201

Fig.	Part No.	Description	Thread	Level Control	Capillary Connections	Tube Connections	Exhaust Filter Connection	Grounding Connection
A	107 121	Safety Waste Cap	S 55	-	-	2	●	-
	107 917	Safety Waste Cap	S 55	-	3	-	●	-
B	107 924	Safety Waste Cap	S 55	-	2	1	●	-
	107 936	Safety Waste Cap	S 55	-	3	-	●	●
C	107 943	Safety Waste Cap	S 55	-	2	1	●	●
	108 142	Safety Waste Cap	S 55	-	4	2	●	-
	108 143	Safety Waste Cap	S 55	-	1	2	●	-
D	108 177	Safety Waste Cap	S 55	-	4	1	●	-
	107 960	Safety Waste Cap	S 55	Mechanical	3	-	●	-
	107 963	Safety Waste Cap	S 55	Mechanical	2	1	●	-
E	108 030	Safety Waste Cap	S 55	Mechanical	3	-	●	●
	108 200	Safety Waste Cap	S 55	Electronically	3	-	●	-
F	108 201	Safety Waste Cap	S 55	Electronically	2	1	●	-

Safety Waste Caps State of the Art - Disposal

 **S 60/61**

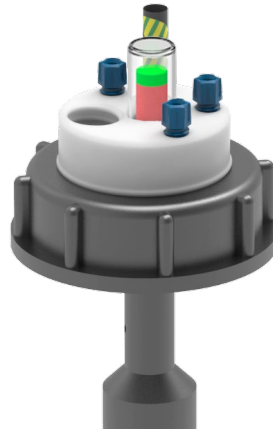
Fig.	Part No.	Description	Thread	Level Control	Capillary Connections	Tube Connections	Exhaust Filter Connection	Grounding Connection
A	307 916	Safety Waste Cap	S 60/61	-	3	-	●	●
	307 918	Safety Waste Cap	S 60/61	-	3	-	●	-
B	307 925	Safety Waste Cap	S 60/61	-	2	1	●	-
C	307 931	Safety Waste Cap	S 60/61	-	4	1	●	-
	307 944	Safety Waste Cap	S 60/61	-	2	1	●	●
	307 961	Safety Waste Cap	S 60/61	Mechanical	3	-	●	-
D	307 500	Safety Waste Cap	S 60/61	-	3	3	●	-
E	307 964	Safety Waste Cap	S 60/61	Mechanical	2	1	●	-
	308 961	Safety Waste Cap	S 60/61	Mechanical	3	-	●	●
	308 964	Safety Waste Cap	S 60/61	Mechanical	2	1	●	●
	308 402	Safety Waste Cap	S 60/61	Electronically	3	-	●	●
F	308 403	Safety Waste Cap	S 60/61	Electronically	2	1	●	-

Safety Waste Caps State of the Art - Disposal

 **B 63**
A 107 038

B 107 050

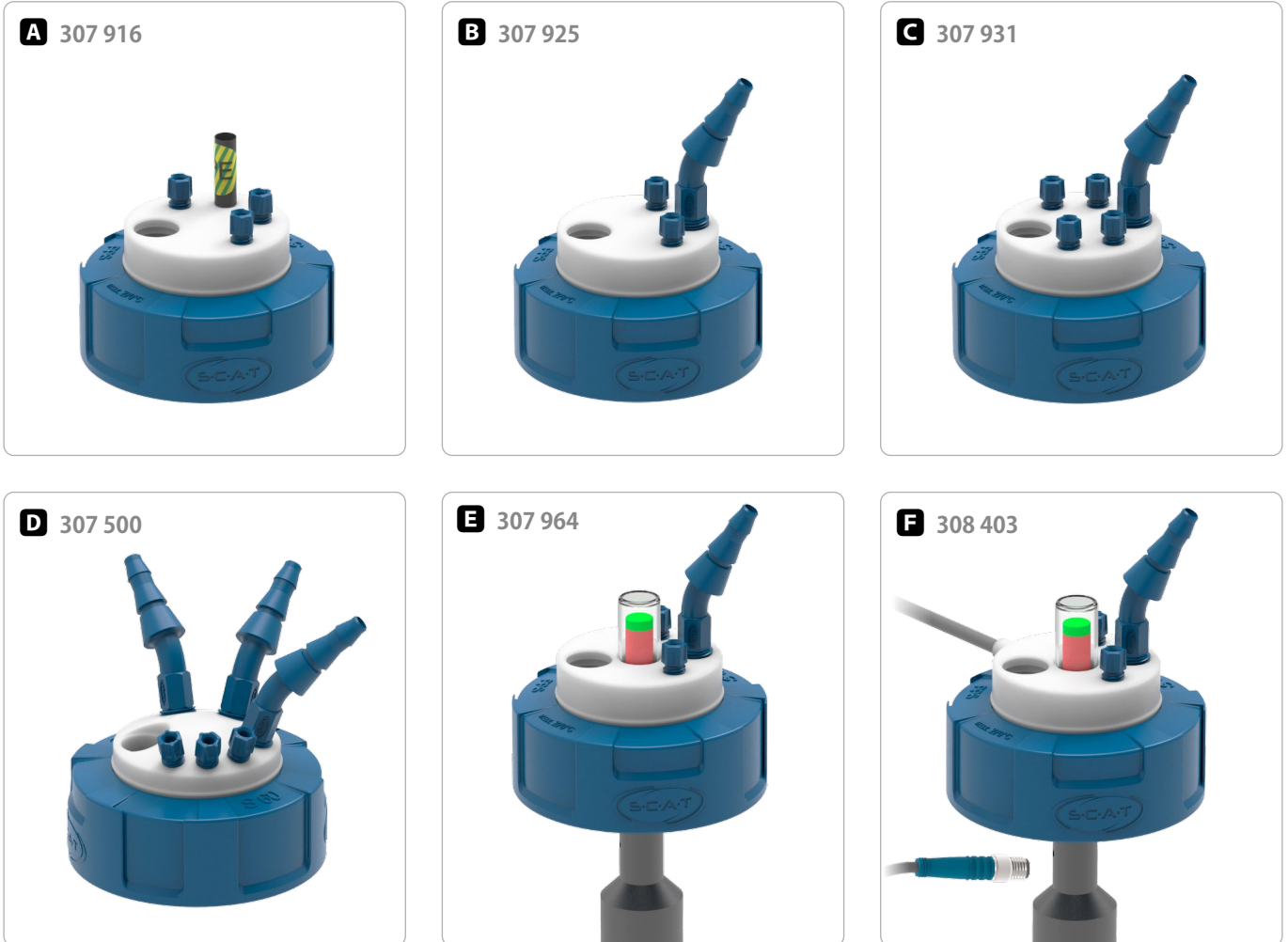
C 107 051

D 107 247

E 107 248

Don't forget - exhaust filter!

Suitable exhaust filters with various operational lifetimes for SCAT Safety Waste Caps you will find on **page 71**.

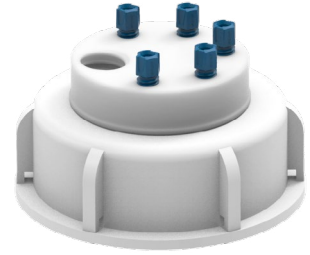

Fig.	Part No.	Description	Thread	Level Control	Capillary Connections	Tube Connections	Exhaust Filter Connection	Grounding Connection
A	107 038	Safety Waste Cap	B 63	-	1	3	●	-
B	107 050	Safety Waste Cap	B 63	-	2	1	●	-
C	107 051	Safety Waste Cap	B 63	-	3	-	●	-
D	107 247	Safety Waste Cap	B 63	Mechanical	2	1	●	-
E	107 248	Safety Waste Cap	B 63	Electronically	2	1	●	-

Safety Waste Caps State of the Art - Disposal

A 108 047

B 108 055

C 108 046

D 107 968

E 107 969

F 108 203



Signalboxes for electronic level control.

Catch the signal from your Safety Waste Cap with electronic level control. Signalboxes you will find on **page 125**.

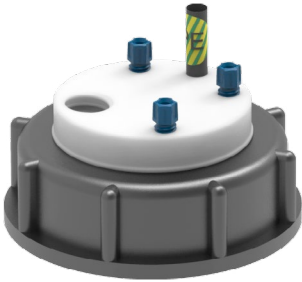
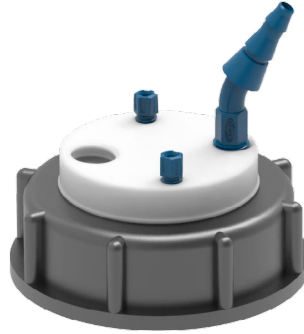

Fig.	Part No.	Description	Thread	Level Control	Capillary Connections	Tube Connections	Exhaust Filter Connection	Grounding Connection
A	108 047	Safety Waste Cap	S 65	-	4	1	●	-
B	108 055	Safety Waste Cap	S 65	-	4	1	●	●
C	108 046	Safety Waste Cap	S 65	-	5	-	●	-
D	107 968	Safety Waste Cap	S 65	Mechanical	4	-	●	-
E	107 969	Safety Waste Cap	S 65	Mechanical	4	1	●	-
F	108 203	Safety Waste Cap	S 65	Electronically	2	1	●	-

Safety Waste Caps State of the Art - Disposal

 **S 70/71**
A 107 915

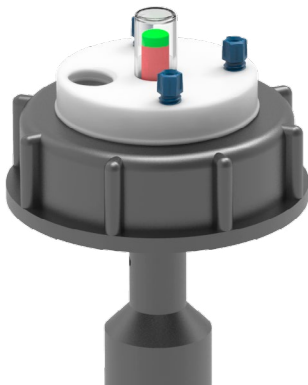
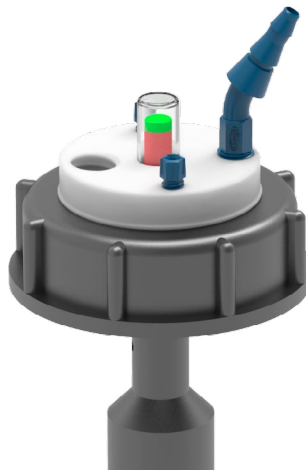
B 107 926

C 107 945

D 107 962

E 107 965

F 108 407

Looking for the right container?

Canisters, bottles and other containers, suitable with the SCAT Safety Waste Caps starting from **page 130**.



Fig.	Part No.	Description	Thread	Level Control	Capillary Connections	Tube Connections	Exhaust Filter Connection	Grounding Connection
	107 913	Safety Waste Cap	S 70/71	-	3	-	●	-
A	107 915	Safety Waste Cap	S 70/71	-	3	-	●	●
B	107 926	Safety Waste Cap	S 70/71	-	2	1	●	-
C	107 945	Safety Waste Cap	S 70/71	-	2	1	●	●
D	107 962	Safety Waste Cap	S 70/71	Mechanical	3	-	●	-
E	107 965	Safety Waste Cap	S 70/71	Mechanical	2	1	●	-
F	108 407	Safety Waste Cap	S 70/71	Electronically	2	1	●	-

Safety Waste Caps State of the Art - Disposal

GLS 80

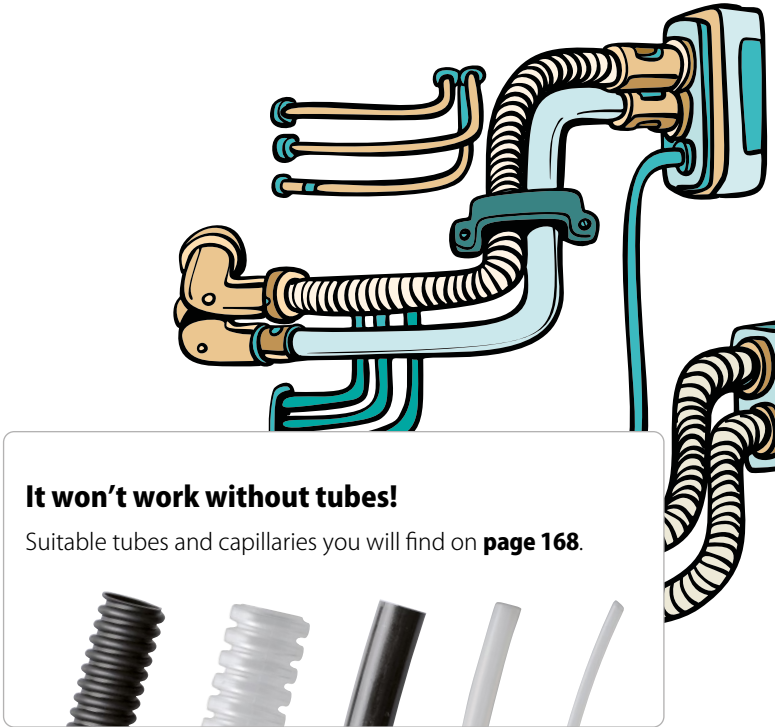
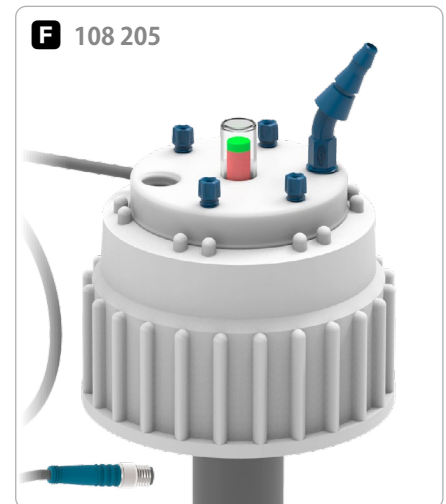
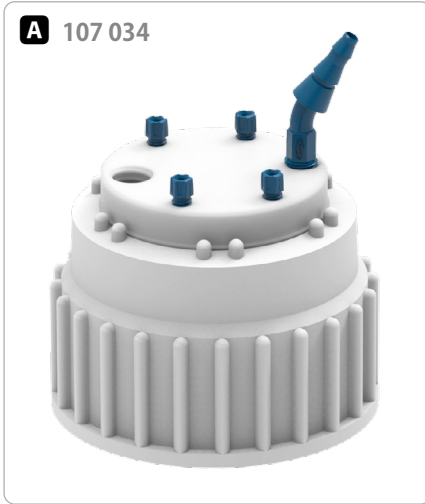

Fig.	Part No.	Description	Thread	Level Control	Capillary Connections	Tube Connections	Exhaust Filter Connection	Grounding Connection
A	107 029	Safety Waste Cap	GLS 80	-	4	-	●	-
B	107 033	Safety Waste Cap	GLS 80	-	4	1	●	-
C	108 206	Safety Waste Cap	GLS 80	Electronically	-	1	●	-

Safety Waste Caps State of the Art - Disposal

Looking for the right container?

Canisters, bottles and other containers, suitable with the SCAT Safety Waste Caps starting from **page 130**.



Fig.	Part No.	Description	Thread	Level Control	Capillary Connections	Tube Connections	Exhaust Filter Connection	Grounding Connection
A	107 034	Safety Waste Cap	B 83	-	4	1	●	-
	107 036	Safety Waste Cap	B 83		4	-	●	-
B	107 052	Safety Waste Cap	B 83	-	4	-	●	●
C	107 053	Safety Waste Cap	B 83	-	4	1	●	●
D	108 156	Safety Waste Cap	B 83	Mechanical	4	1	●	-
E	108 302	Safety Waste Cap	B 83	Mechanical	8	2	●	-
F	108 205	Safety Waste Cap	B 83	Electronically	4	1	●	-

Safety Waste Caps State of the Art - Disposal

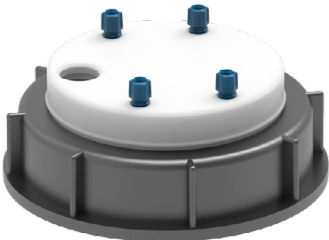
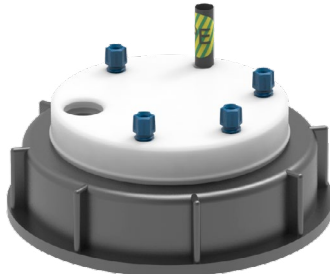
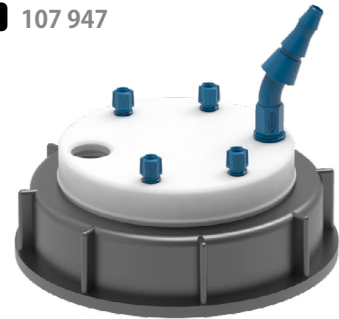
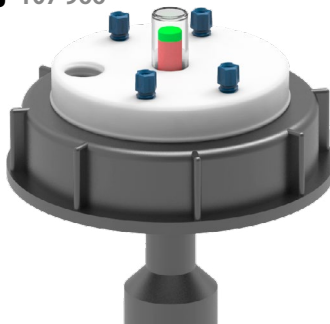
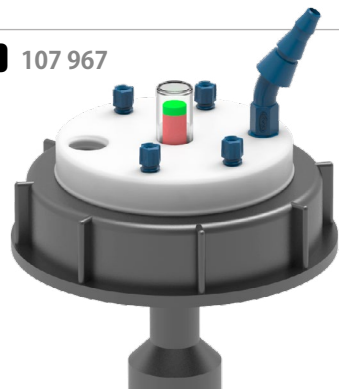
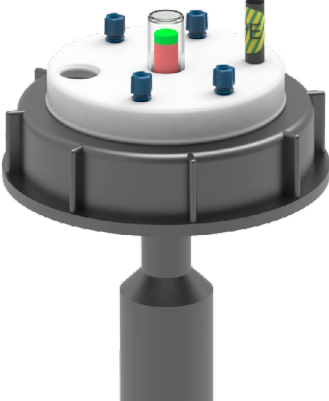
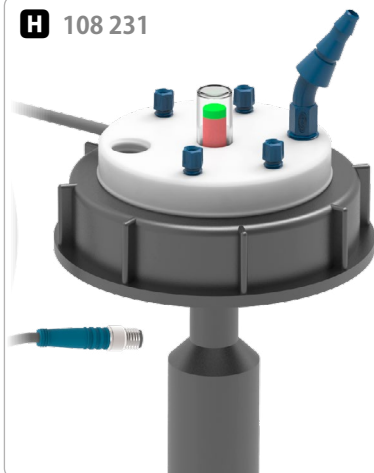
A 107 927**B** 107 928**C** 107 947**D** 107 949**E** 107 966**F** 107 967**G** 108 031**H** 108 231

Don't forget - exhaust filter!

Suitable exhaust filters with various operational lifetimes for SCAT Safety Waste Caps you will find on **page 71**.



Fig.	Part No.	Description	Thread	Level Control	Capillary Connections	Tube Connections	Exhaust Filter Connection	Grounding Connection
A	107 927	Safety Waste Cap	S 90	-	4	-	●	-
B	107 928	Safety Waste Cap	S 90	-	4	-	●	●
C	107 947	Safety Waste Cap	S 90	-	4	1	●	-
D	107 949	Safety Waste Cap	S 90	-	4	1	●	●
E	107 966	Safety Waste Cap	S 90	Mechanical	4	-	●	-
F	107 967	Safety Waste Cap	S 90	Mechanical	4	1	●	-
G	108 031	Safety Waste Cap	S 90	Mechanical	4	-	●	●
H	108 231	Safety Waste Cap	S 90	Electronically	4	1	●	-

Safety Waste Caps State of the Art - Disposal

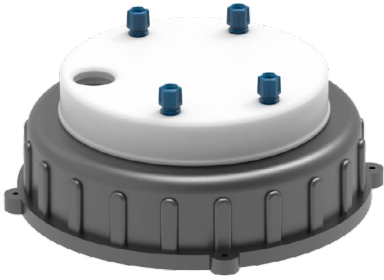
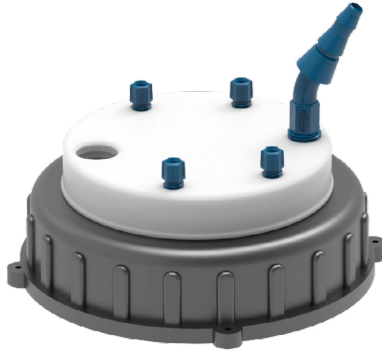
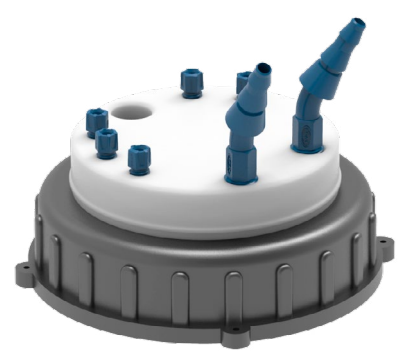
A 107 256

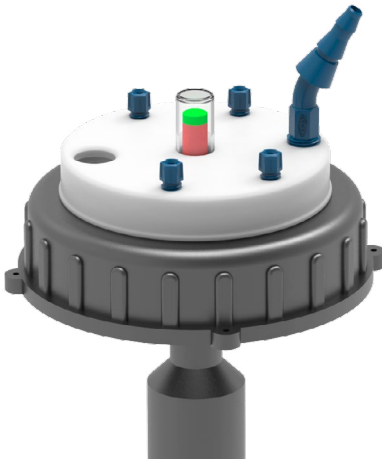
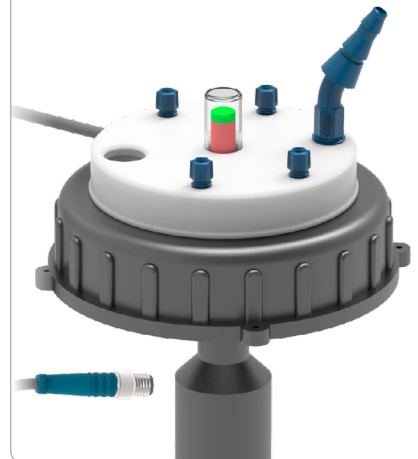
B 107 257

C 107 987

D 117 987

E 107 258

F 107 259

Signalboxes for electronic level control.

Catch the signal from your Safety Waste Cap with electronic level control. Signalboxes you will find on **page 125**.



Fig.	Part No.	Description	Thread	Level Control	Capillary Connections	Tube Connections	Exhaust Filter Connection	Grounding Connection
A	107 256	Safety Waste Cap	S 95	-	4	-	●	-
B	107 257	Safety Waste Cap	S 95	-	4	1	●	-
C	107 987	Safety Waste Cap	S 95	-	5	2	●	-
D	117 987	Safety Waste Cap	S 95	-	12	-	●	-
E	107 258	Safety Waste Cap	S 95	Mechanical	4	1	●	-
F	107 259	Safety Waste Cap	S 95	Electronically	4	1	●	-

HPLC Disposal Sets

The Plug-and-Play Solution

Safety Waste Cap, canister, exhaust air filter and comprehensive accessories combined in a HPLC disposal set for direct start-up of your disposal.

HPLC Disposal Set

Scope of Delivery (307 307)

Waste canister

- GL 45 Thread
- 5 Litres
- PE-HD



1x

Safety Waste Cap

- GL 45 Thread
- 2x Capillary connection
- 1x Tube connection
- 1x Exhaust filter connection



1x

Exhaust filter

- Size M
- Operational lifetime: 6 months



1x

Tube connector, stepped, curved

- Ø 5 - 11.5 mm OD
- PP, blue



1x

Fitting for capillaries

- Ø 2.3 mm ID
- PFA, violet



2x

Fitting for capillaries

- Ø 3.2 mm ID
- PFA, blue



2x

Blind plug for capillary connection

- PFA, colourless



2x

HPLC Disposal Sets

A 307 307



Fig.	Part No.	Description	Contents		
A	307 307	HPLC Disposal Set 1	Quantity	Description	See also
			1x	Safety Waste Cap, GL 45 (307 923)	► Page 73
			1x	5 Litre canister, PE-HD (107 951)	► Page 136
	307 310	HPLC Disposal Set 2	Quantity	Description	See also
			1x	Safety Waste Cap, GL 45 (307 923)	► Page 73
			1x	10 Litre canister, PE-HD (107 952)	► Page 136
			1x	Exhaust filter M (410 535)	► Page 71
	307 328	HPLC Disposal Set 3	Quantity	Description	See also
			1x	Safety Waste Cap, S 50 (108 025)	► Page 74
			1x	5 Litre space-saving canister, PP (107 998)	► Page 136
			1x	Exhaust filter S (410 534)	► Page 71
	307 355	HPLC Disposal Set 4	Quantity	Description	See also
			1x	Safety Waste Cap, S 60/61 (307 925)	► Page 78
			1x	12 Litres canister, PE-HD (107 731)	► Page 138
			1x	Exhaust filter M (410 535)	► Page 71

LISA Safety Waste Cap

Collect HPLC / UHPLC waste safely.

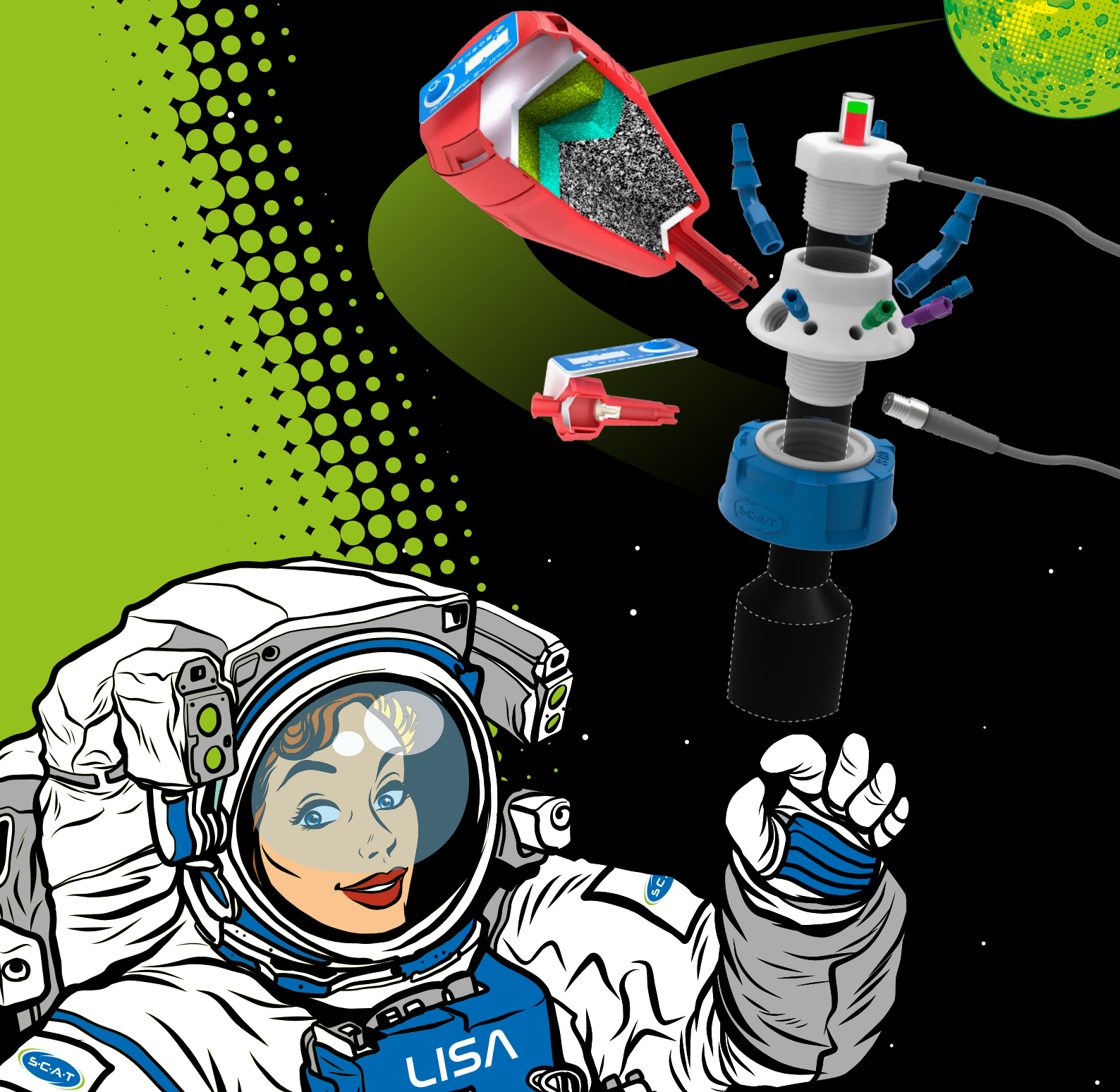

LISA

Technical Details

Blind Plug

- In addition to blind plugs, various different components from our product range can be connected to the M 30 x 35 thread

Modular Concept

- The „satellite“ module is extendible with additional features, e.g. level controls, funnels, lab stirrers or...

Convertible

- Thanks to the exhaust filter blind plug, the „Waste Cap“ (disposal) can be converted into a „Safety Cap“ (supply)
- The air valve fits into the capillary connection

PP Tube Connectors

- Connections for larger tubes, having an inner diameter of 5.0 - 11.5 mm. Within the scope of delivery of LISA: 3 tube connectors, with an NPT 1/8" thread.

Satellite made of PTFE

- Our satellite is made of (pure) PTFE, for optimal chemical resistance
- The cap can be rotated through 360°, in order to allow for simple exchange of the container, without any resultant twisting of tubing

PFA Fittings

- Improved design, for even easier connection of capillaries. Excellent chemical resistance. Flammability Classification V-0, as per UL-94.
- Has standard connections for HPLC capillaries of outer diameter 1.6 mm, 2.3 mm or 3.2 mm. The scope of delivery of the LISA includes 12 fittings with a UNF 1/4" thread.

Screw Cap made of PPS (GL 45 & S 60)

- Suitable for various collecting containers
- Simple installation and easy exchange
- Autoclavable / sterilizable, up to 200°C, Flammability Classification V-0, as per UL-94
- Stable Construction
- Improved handling

GL 14 Connection for Exhaust Filter

- The Safety Waste Cap LISA has a connection for all exhaust filters from our product range. With the aid of optimized active carbon, SCAT exhaust filters block harmful vapours, thereby ensuring for safe pressure equalization in the waste containers of your HPLC systems.

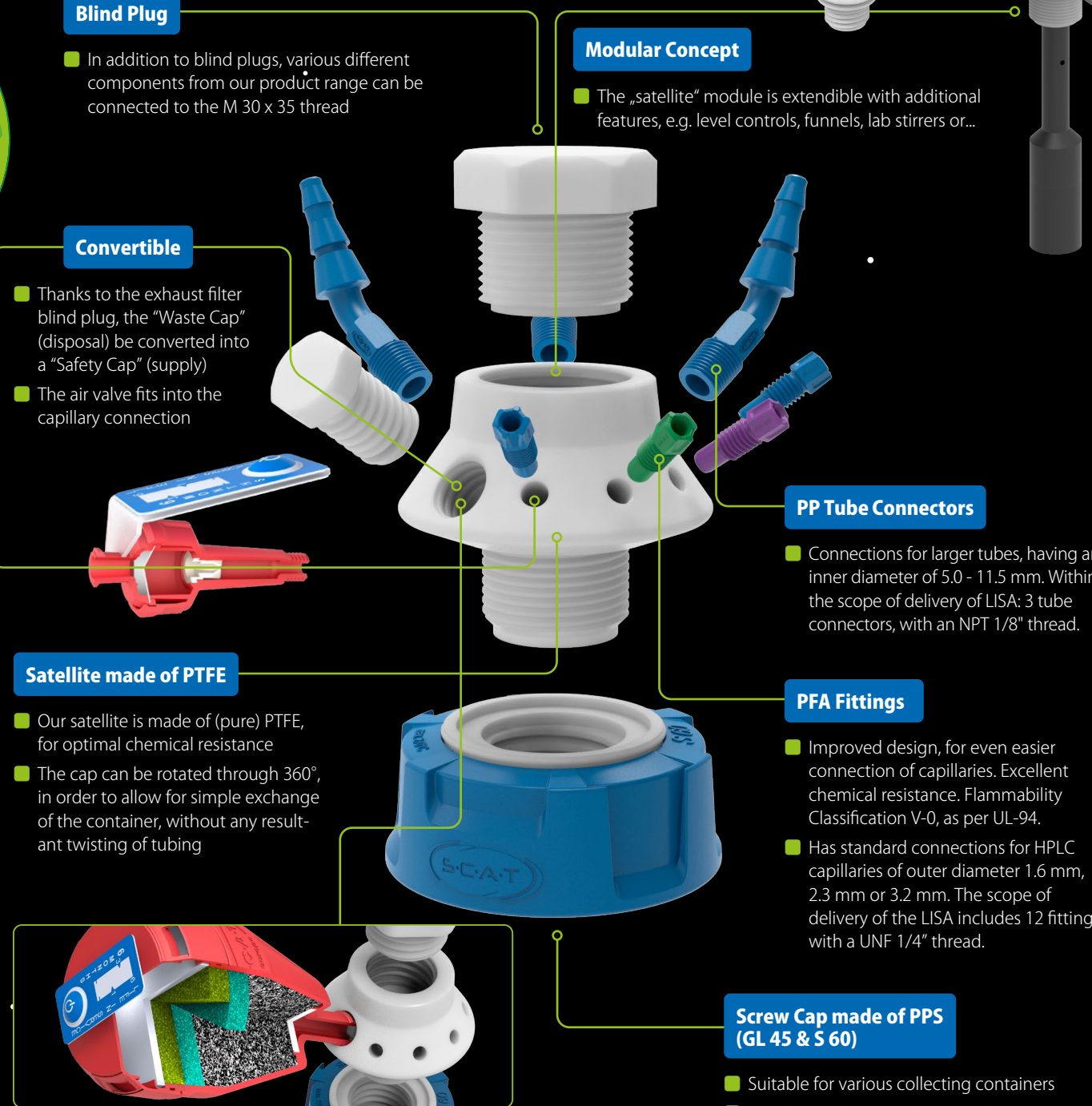

Safety Waste Cap LISA

Scope of Delivery **A**

Blind plug satellite LISA

■ PTFE, white



1x

Safety Waste Cap LISA satellite with screw cap

■ PTFE, white



1x

Blind plug for exhaust filter connection

■ PTFE, white



1x

Tube connector, stepped, curved

■ Ø 5 - 11.5 mm OD

■ PP, blue



3x

Blind plug for tube connection

■ PTFE, white



3x

Fitting for capillaries

■ Ø 1.6 mm ID

■ PFA, green



4x

Fitting for capillaries

■ Ø 2.2 mm ID

■ PFA, violet



4x

Fitting for capillaries

■ Ø 3.2 mm ID

■ PFA, blue



4x

Blind plug for capillary connection

■ PFA, colourless



4x



Also available as electrostatic conductive version.

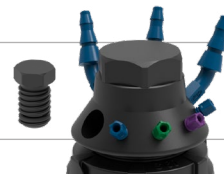

Fig.	Part No.	Description	Thread	Capillary Connections	Tube Connections	Blind Plugs	Exhaust Filter Connection	Electrostatic conductive
A	350 045	Safety Waste Cap LISA	GL 45	4x	3x	9x	●	-
	450 045	Safety Waste Cap LISA	GL 45	4x	3x	9x	●	●
	350 050	Safety Waste Cap LISA	S 50	4x	3x	9x	●	-
	450 050	Safety Waste Cap LISA	S 50	4x	3x	9x	●	●
	350 051	Safety Waste Cap LISA	S 51	4x	3x	9x	●	-
	350 053	Safety Waste Cap LISA	B 53	4x	3x	9x	●	-
	350 055	Safety Waste Cap LISA	S 55	4x	3x	9x	●	-
	350 060	Safety Waste Cap LISA	S 60/61	4x	3x	9x	●	-
	450 060	Safety Waste Cap LISA	S 60/61	4x	3x	9x	●	●
	350 063	Safety Waste Cap LISA	B 63	4x	3x	9x	●	-
	350 065	Safety Waste Cap LISA	S 65	4x	3x	9x	●	-
	350 070	Safety Waste Cap LISA	S 70/71	4x	3x	9x	●	-
	350 083	Safety Waste Cap LISA	B 83	4x	3x	9x	●	-
	350 090	Safety Waste Cap LISA	S 90	4x	3x	9x	●	-
	350 095	Safety Waste Cap LISA	S 95	4x	3x	9x	●	-

Safety Waste Cap LISA Extensions and Accessories

Expandable

- The modular concept of LISA makes it easy to expand the number of connections. Extensions and accessories can be found on the next page.



Modular Concept

- The "satellite" module is extendible with additional features, e.g. funnels, level control and tube adapters

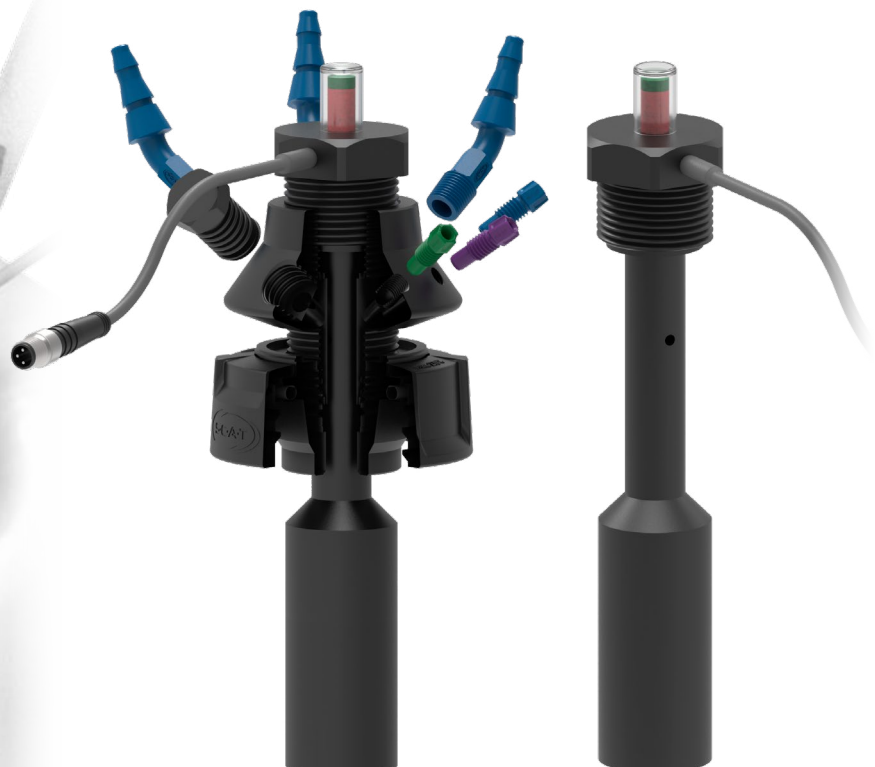
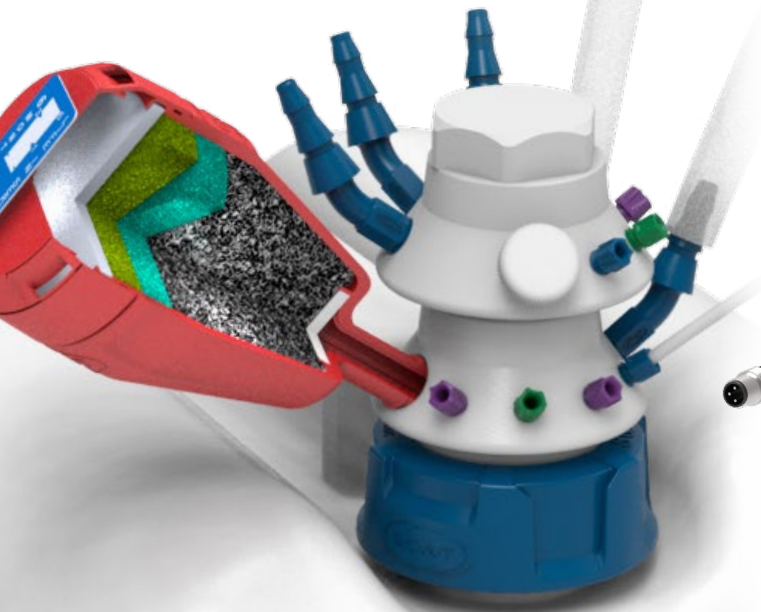

Safety Waste Cap LISA Extensions and Accessories

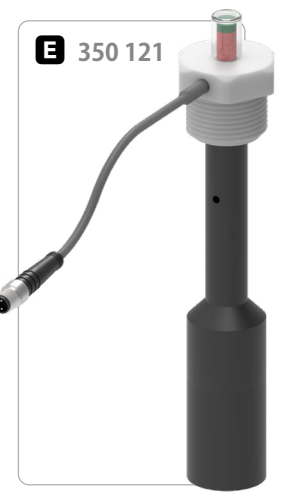
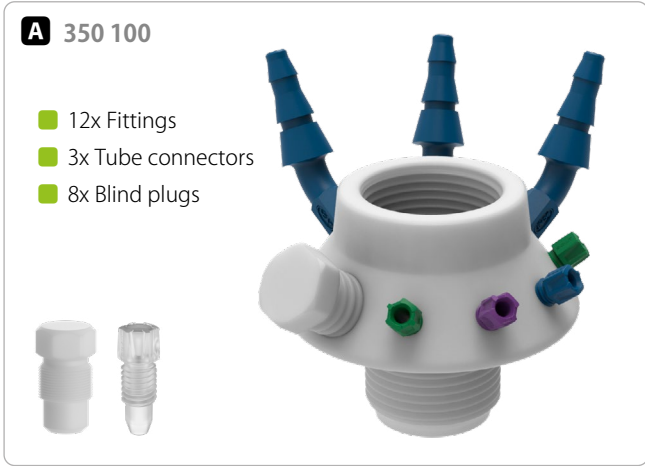

Fig.	Art. Nr.	Description	Thread	Electrostatic conductive	Unit
A	350 100	Extension satellite LISA, PTFE	M 30 x 35	-	1
B	450 100	Extension satellite LISA, PTFE-EL	M 30 x 35	•	1

Safety Waste Cap LISA Extensions and Accessories



Fig.	Fig.	Description	Thread	Electrostatic conductive	Unit
C	350 120	Funnel with lid MARCO for LISA, PE-HD, removable sieve	M 30 x 35	-	1
D	450 120	Funnel with lid MARCO for LISA, PE-HD-EL, removable sieve	M 30 x 35	●	1
E	350 121	Level Control for LISA	M 30 x 35	-	1
F	450 121	Level Control for LISA	M 30 x 35	●	1
G	350 110	Blind plug satellite LISA, PTFE	M 30 x 35	-	1
H	450 110	Blind plug satellite LISA, PTFE-EL	M 30 x 35	●	1
I	410 534	Exhaust filter S, V3.0, with change indicator	GL 14	-	1
	490 335	Reserve pack exhaust filter S, V3.0, with change indicator	GL 14	-	4
J	410 535	Exhaust filter M, V3.0, with change indicator	GL 14	-	1
	490 336	Reserve pack exhaust filter M, V3.0, with change indicator	GL 14	-	2
K	407 986	Exhaust filter L, V3.0, with change indicator	GL 14	-	1
	490 986	Reserve pack exhaust filter L, V3.0, with change indicator	GL 14	-	2
L	117 808	Tube connector, stepped, curved, 5.0 - 11.5 mm OD	NPT 1/8"	-	1
M	160 506	Blind plug for tube connection, PTFE	NPT 1/8"	-	1
N	160 523	Blind plug for tube connection, PTFE-EL	NPT 1/8"	●	1
O	107 620	Blind plug, PTFE, for exhaust filter connection	GL 14	-	1
P	107 680	Blind plug, PTFE-EL, for exhaust filter connection	GL 14	●	1
Q	107 061	PFA Fitting with integrated ferrule, 1.6 mm ID, green	UNF 1/4"	-	5
R	107 059	PFA Fitting with integrated ferrule, 2.3 mm ID, violet	UNF 1/4"	-	5
S	107 063	PFA Fitting with integrated ferrule, 3.2 mm ID, blue	UNF 1/4"	-	5
T	160 502	Blind plug for capillary connection, PFA, colourless	UNF 1/4"	-	5
	160 501	Blind plug for capillary connection, PFA, colourless	UNF 1/4"	-	10

JAN Universal Waste Hub

The clever all-rounder for liquid waste disposal.



JAN Benefits

✓ The Universal Solution for Liquid Waste!

The new Universal Waste Hub JAN is not only equipped to deal with solvent waste from HPLC units, it is also able to handle other waste liquids, both safely and without smelling.

✓ State-of -the-Art Safety and Environmental Protection

The integrated exhaust filter prevents the exit of damaging vapours and ensures for a safe pressure equalization within the container. With Fire Protection V-0 as per UL 94!

✓ The All-in-One Solution for Liquid Waste in the Laboratory!

A complete spectrum of supply (24 components) is always available, for all eventualities and all connection possibilities.

✓ DIN- / ISO- / ASTM-tested Material

The materials used are tested per official DIN/ISO/ASTM Standards, for optimum durability and safety, also w.r.t. aggressive chemicals.



JAN = LISA with MARCO and exhaust filter.

The Universal Waste Hub JAN uses the "satellite" based on the Safety Waste Cap LISA and is standardly equipped with safety funnel MARCO and including an exhaust filter.



Universal Waste Hub JAN Technical Details



Universal Waste Hub JAN Technical Details

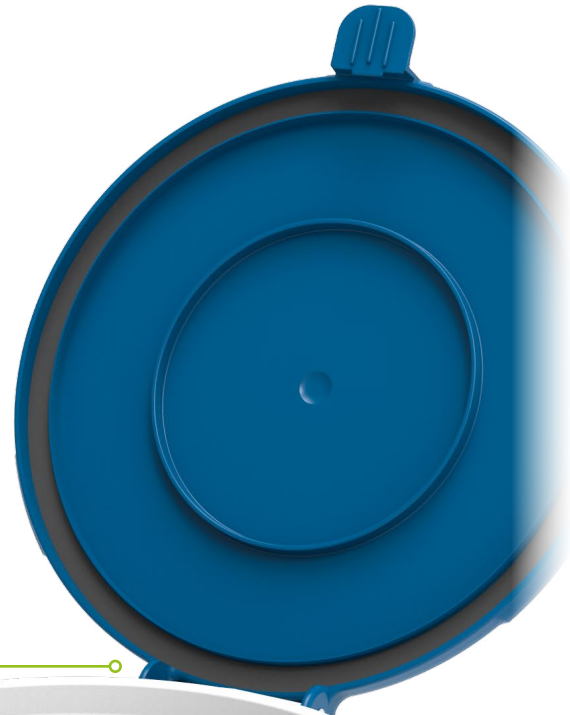

Stable Hinge

- Double-screw hinge made of rust-free stainless steel: for high durability and stability

Fire Protection (V-0)

- Filter housing constructed of partially crystalline PP, certified according to Fire Protection Class V-0 as per UL-94

4 HPLC Connections (PFA)

- Always fits: fittings for capillaries of sizes 1.6, 2.3 and 3.2 mm, and for every connector, are within the scope of delivery

3 Tube Connectors (PP)

- For more flexibility when connecting your tubing: the tube connector is suitable for tubes with an inner diameter of 5 to 11.5 mm



Accessories supplied!

Fittings, tube connectors and blind plugs are included in every size.

ID 1.6 mm 2.3 mm 3.2 mm -



Universal Waste Hub JAN Standard: Fully-Equipped (25 Parts)



Universal Waste Hub JAN

- S 60/61 Thread
- 4 HPLC connections
- 3 Tube connections
- 1 Connection for exhaust filter
- Safety funnel
- Removable sieve
- With lid



1x

Fitting for capillaries

- Ø 1.6 mm ID
- PFA, green



4x

Fitting for capillaries

- Ø 2.3 mm ID
- PFA, violet



4x

Fitting for capillaries

- Ø 3.2 mm ID
- PFA, blue



4x

Blind plug for capillary connection

- PFA, colourless



4x

Tube connector, stepped, curved

- Ø 5 - 11.5 mm OD
- PP, blue



3x

Blind plug for tube connection

- PTFE, white



3x

Exhaust filter

- Size M
- Lifetime: 6 month



1x

Blind plug for exhaust filter connection

- PTFE, white



1x

Fig.	Part No.	Description	Contents		
A	320 060	Universal Waste Hub JAN	Quantity	Description	See also
			1x	Universal Waste Hub JAN	► Page 98
			4x	PFA Fitting, 1.6 mm ID, green	► Page 156
			4x	PFA Fitting, 2.3 mm ID, violet	► Page 156
			4x	PFA Fitting, 3.2 mm ID, blue	► Page 156
			4x	Blind plug for capillary connection, PFA, colourless	► Page 156
			3x	Tube connector, stepped, curved, Ø 5 - 11.5 mm OD	► Page 158
			3x	Blind plug for tube connection, PTFE, white	► Page 159
			1x	Exhaust filter M, V3.0, with splash protection and change indicator	► Page 71
1x	Blind plug for exhaust filter connection, PTFE, white	► Page 154			

Алматы (727)345-47-04
 Ангарск (3955)60-70-56
 Архангельск (8182)63-90-72
 Астрахань (8512)99-46-04
 Барнаул (3852)73-04-60
 Белгород (4722)40-23-64
 Благовещенск (4162)22-76-07
 Брянск (4832)59-03-52
 Владивосток (423)249-28-31
 Владикавказ (8672)28-90-48
 Владимир (4922)49-43-18
 Волгоград (844)278-03-48
 Вологда (8172)26-41-59
 Воронеж (473)204-51-73
 Екатеринбург (343)384-55-89

Иваново (4932)77-34-06
 Ижевск (3412)26-03-58
 Иркутск (395)279-98-46
 Казань (843)206-01-48
 Калининград (4012)72-03-81
 Калуга (4842)92-23-67
 Кемерово (3842)65-04-62
 Киров (8332)68-02-04
 Коломна (4966)23-41-49
 Кострома (4942)77-07-48
 Краснодар (861)203-40-90
 Красноярск (391)204-63-61
 Курск (4712)77-13-04
 Курган (3522)50-90-47
 Липецк (4742)52-20-81

Магнитогорск (3519)55-03-13
 Москва (495)268-04-70
 Мурманск (8152)59-64-93
 Набережные Челны (8552)20-53-41
 Нижний Новгород (831)429-08-12
 Новокузнецк (3843)20-46-81
 Ноябрьск (3496)41-32-12
 Новосибирск (383)227-86-73
 Омск (3812)21-46-40
 Орел (4862)44-53-42
 Оренбург (3532)37-68-04
 Пенза (8412)22-31-16
 Петрозаводск (8142)55-98-37
 Псков (8112)59-10-37
 Пермь (342)205-81-47

Ростов-на-Дону (863)308-18-15
 Рязань (4912)46-61-64
 Самара (846)206-03-16
 Санкт-Петербург (812)309-46-40
 Саратов (845)249-38-78
 Севастополь (8692)22-31-93
 Саранск (8342)22-96-24
 Симферополь (3652)67-13-56
 Смоленск (4812)29-41-54
 Сочи (862)225-72-31
 Ставрополь (8652)20-65-13
 Сургут (3462)77-98-35
 Сыктывкар (8212)25-95-17
 Тамбов (4752)50-40-97
 Тверь (4822)63-31-35

Тольятти (8482)63-91-07
 Томск (3822)98-41-53
 Тула (4872)33-79-87
 Тюмень (3452)66-21-18
 Ульяновск (8422)24-23-59
 Улан-Удэ (3012)59-97-51
 Уфа (347)229-48-12
 Хабаровск (4212)92-98-04
 Чебоксары (8352)28-53-07
 Челябинск (351)202-03-61
 Череповец (8202)49-02-64
 Чита (3022)38-34-83
 Якутск (4112)23-90-97
 Ярославль (4852)69-52-93

Россия +7(495)268-04-70

Казахстан +7(727)345-47-04

Беларусь +(375)257-127-884

Узбекистан +998(71)205-18-59

Киргизия +996(312)96-26-47

<https://scat.nt-rt.ru/> || sqt@nt-rt.ru

Universal Waste Hub JAN Ordering Information

A 320 060



B



Information about "delivery with adapter":

The Universal Waste Hub JAN is available for various container threads. In order to manufacture, both ecologically and economically, we can deliver some variants together with a thread adapter.



Electrostatic conductive

Models in black are made of electrostatic conductive PE-HD and are additionally supplied with a grounding cable and clamp.

Fig.	Part No.	Description	Thread	Electrostatic conductive	Delivery with Adapter
	320 045	Universal Waste Hub JAN	GL 45	-	-
	420 045	Universal Waste Hub JAN	GL 45	●	-
	320 050	Universal Waste Hub JAN	S 50	-	●
	320 051	Universal Waste Hub JAN	S 51	-	●
	320 053	Universal Waste Hub JAN	B 53	-	●
	320 055	Universal Waste Hub JAN	S 55	-	-
A	320 060	Universal Waste Hub JAN	S 60/61	-	-
B	420 060	Universal Waste Hub JAN	S 60/61	●	-
	320 063	Universal Waste Hub JAN	B 63	-	●
	320 065	Universal Waste Hub JAN	S 65	-	●
	320 070	Universal Waste Hub JAN	S 70/71	-	●
	320 083	Universal Waste Hub JAN	B 83	-	●
	320 090	Universal Waste Hub JAN	S 90	-	●
	320 095	Universal Waste Hub JAN	S 95	-	●